

TLI-MS02

INFRARED MOTION SENSOR

SPECIFICATION

Power Source	220-240V/AC
Power Frequency	50/60Hz
Ambient Light	<3-2000LUX (adjustable)
Time Delay	Min.10sec±3sec Max.15min±2min
Rated Load	Max.1200/300W
Detection Range	360°
Detection Distance	6m max(<24 °C)
Working Temperature	-20~+40°C
Working Humidity	<93%RH
Power Consumption	approx 0.5W
Installation Height	2.2-4m
Detection Moving Speed	0.6-1.5m/s
Ingress Protection (IP Rating)	IP20

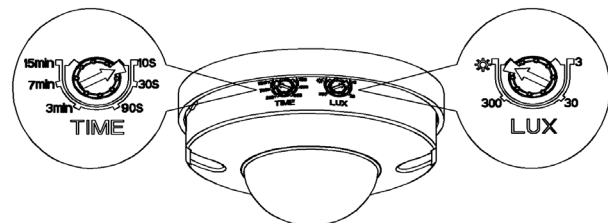
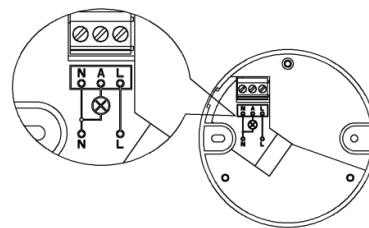
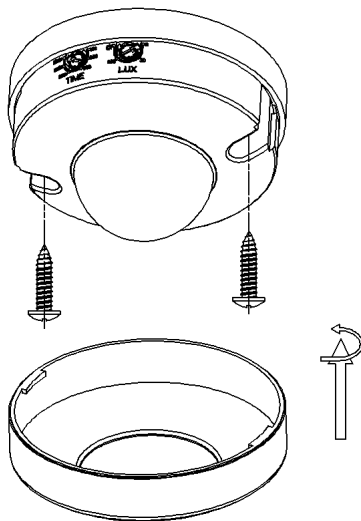
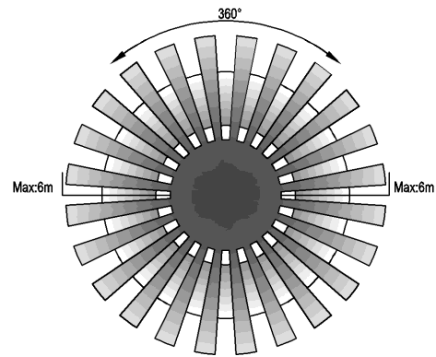
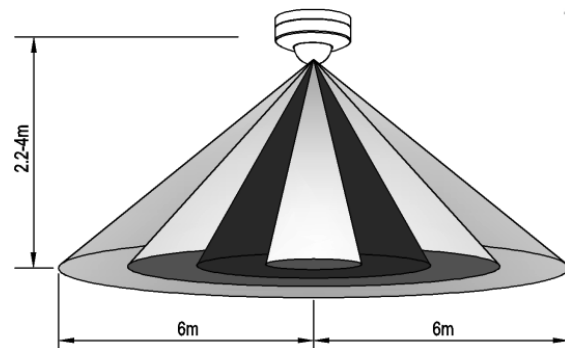

DATA SHEET

CODE	INPUT VOLTAGE	DIMENSION	Installation Height	Detection Distance	Moving Speed
TLI-MS02	AC220-240V	Ø126 x 65 mm	2.2-4m	12m max(<24 °C)	0.6/1.5(m/s)